

*Patented!  
Rotating hand  
chain guide*



Available in explosion proof version (please see page 448).



Chain guide



High quality encapsulated ball bearings and sliding bushes for smooth and effortless operation.

## Hand chain hoist model Yalelift 360

Capacity 500 - 20000 kg

Areas of operation as well as operator conditions have been improved far beyond those of a classical hand chain hoist.

### Features

- The enclosed robust stamped steel housing protects all internal components even in the toughest conditions.
- The extremely low headroom allows maximum use of the lifting height.
- The revolutionary 360° rotating hand chain guide allows the operator to work from virtually any position, in confined spaces or above the load. The Yalelift can even be operated from the side of the load which also makes it possible to use the hoist for horizontal pulling or tensioning. Due to the additional flexibility, the operator is no longer forced to work in the danger zone near the load.
- The brake system is extremely quiet and guarantees operational safety and improved serviceability due to omission of the vulnerable ratchet pawls. All parts are made of high quality materials, additionally zinc-plated or yellow-chromated to increase corrosion prevention.
- Chain guide and gearbox are almost totally enclosed. Even under the toughest conditions the internal gearbox remains protected.
- The hardened load sheave with four precision machined pockets ensures accurate movement of the load chain.
- The surface protected zinc-plated alloy steel load chains fulfil all requirements of current national and international standards and regulations.
- Drop forged load and suspension hooks that yield under overload instead of breaking, are made of high tensile steel. The hooks are fitted with robust safety latches and rotate 360°.

### Options

- Adjustable overload protection device.
- Chain container
- Corrosion resistant version

## INFO

Easy modification from Yalelift 360 to Yalelift IT is possible.

Yale hoists and trolleys are not designed for passenger elevation applications and must not be used for this purpose.

## Hand chain hoist model Yalelift 360 20t

Capacity 20000 kg

The brake system used in the Yalelift series is also employed in the Yalelift 360 20t, setting standards in terms of operational safety and serviceability. The brake is extremely quiet and wear resistant. In spite of its high capacity, the Yalelift 360 20t features a compact design.

### Features

- All components are made of high quality materials, some components are zinc-plated or yellow-chromated for added corrosion protection. This ensures that also heaviest loads are held reliably.
- The enclosed robust stamped steel body resists in the toughest conditions and allows outside operation.
- The hardened load sheave with five precision machined pockets ensures accurate movement of the load chain.
- The low headroom (hook-to-hook dimension 1010 mm) allows maximum use of the lifting height.
- The Yalelift 360 20t is equipped with six chain falls only which results in higher speed and lower weight.

### Options

- Adjustable overload protection device.
- Chain container
- Corrosion resistant version



The robust stamped steel housing with four stay bolts is resistant to the toughest working conditions.



The precisely machined load sheave ensures accurate movement of the load chain.

## Technical data model Yalelift

Model	EAN-No. 4025092*	Capacity kg	Number of chain falls	Chain dimensions d x p mm	Lift per 1 m hand chain overhaul mm	Handle pull at WLL daN	Weight at standard lift (3 m) kg
YL 500	*288545	500	1	5x15	33	21	9
YL 1000	*288552	1000	1	6x18	20	30	13
YL 2000	*288569	2000	1	8x24	14	32	20
YL 3000	*941129	3000	1	10x30	12	38	29
YL 5000	*941143	5000	2	10x30	6	34	38
YL 10000	*291842	10000	3	10x30	4	44	71
YL 20000	*292153	20000	6	10x30	2	2x44	196



Dimensions model Yalelift

Model	YL 500	YL 1000	YL 2000	YL 3000	YL 5000	YL 10000	YL 20000
A min., mm	300	335	395	520	654	825	1065
B, mm	17	22	30	38	45	68	85
C, mm	24	29	35	40	47	68	64
D, mm	133	156	182	220	220	220	303
E, mm	148	175	203	250	250	383	555
F, mm	148	167	194	219	219	219	250
G, mm	139	164	192	225	242	326	391
H, mm	206	242	283	335	352	436	501
I, mm	24	24	31	34	21	136	-
K, mm	61	70	83	95	95	95	396
L, mm	87	97	111	124	124	124	125
M, mm	110	125	156	178	285	401	471
N, mm	14	19	22	30	37	50	56

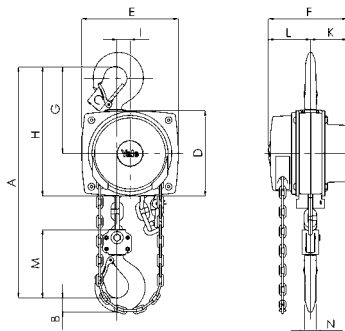

Model Yalelift 360, 500 - 3000 kg, single fall

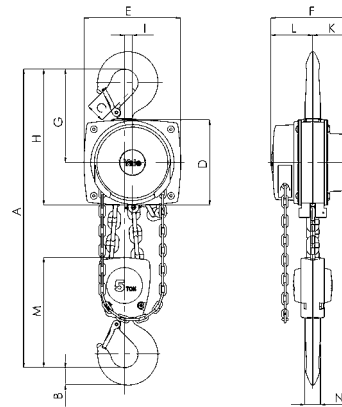

Model Yalelift 360, 5000 kg, double fall

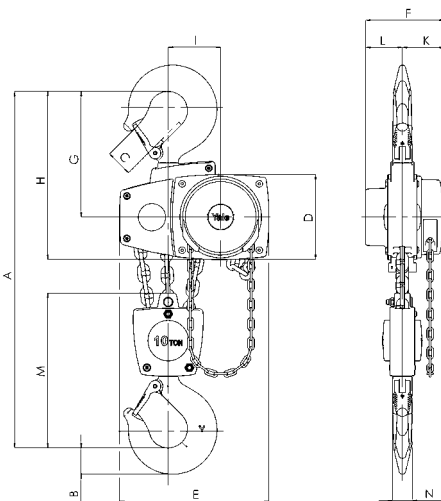

Model Yalelift 360, 10000 kg, three fall

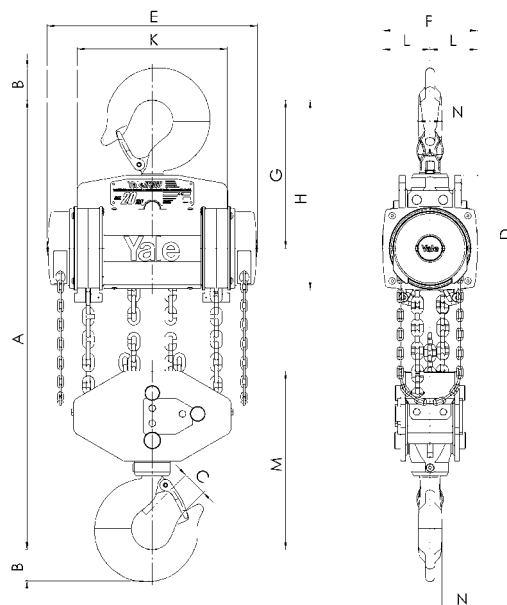

Model Yalelift 360, 20000 kg, six fall



## Hand chain hoist model VSIII

Capacity 250 - 5000 kg

The newly designed hand chain hoist VSIII is an innovative further development introduced by Yale. The improved hand chain guide prevents canting or jamming of the hand chain, leading to a smooth running of the chain. High quality bearings on side plates, gearbox and load chain sheave ensure smooth operation of load chain and drive pinion.

Optimized hand forces set standards for easy operation.

### Features

- Strong bolts between side plates and housing cover and the reinforced hand wheel cover ensure increased stability.
- Precision machined guide rollers ensure smooth running of the load chain.
- High quality bearings for gearbox, side plates and load chain sheave permit a long service life.
- Zinc-plated and yellow-chromated brake parts and guide rollers ensure increased corrosion protection.
- Zinc-plated load chain as standard for added corrosion protection.

### Options

- Overload protection device
- Chain container



Load chain sheave with needle bearing



Side plate with ball bearing



Housing cover with ball bearing

## Technical data model VSIII

Model	EAN-No. 4025092*	Capacity in kg/ number of chain falls	Chain dimensions d x p mm	Lift per 1 m hand chain overhaul mm	Handle pull at WLL daN	Weight at standard lift (3 m) kg
VSIII 0,25/1	*665322	250/1	4x12	50	20	3.9
VSIII 0,5/1	*949545	500/1	5x15	26	21	9.0
VSIII 1,0/1	*949927	1000/1	6x18	24	24	11.5
VSIII 1,5/1	*593854	1500/1	8x24	17	30	17.5
VSIII 2,0/1	*949934	2000/1	8x24	19	32	19.0
VSIII 2,0/2	*949941	2000/2	6x18	15	29	17.3
VSIII 3,0/1	*949958	3000/1	10x30	12	40	31.0
VSIII 3,0/2	*949965	3000/2	8x24	10	37	27.0
VSIII 5,0/2	*949972	5000/2	10x30	8	41	43.0

## Dimensions model VSIII

Model	VSIII 0,25/1	VSIII 0,5/1	VSIII 1,0/1	VSIII 1,5/1	VSIII 2,0/1	VSIII 2,0/2	VSIII 3,0/1	VSIII 3,0/2	VSIII 5,0/2
A min., mm	290	350	380	450	460	490	570	580	700
B, mm	12	21	27	33	37	37	46	46	56
C, mm	26	28	32	37	41	41	44	44	50
D, mm	11	16	19	22	27	27	31	31	37
E, mm	118	145	158	180	205	170	240	220	250
F, mm	113	140	155	175	180	155	210	175	190
G, mm	65	80	87	85	94	87	110	94	95
H, mm	48	60	68	90	86	68	100	81	95
K, mm	190	240	270	300	320	285	370	340	410

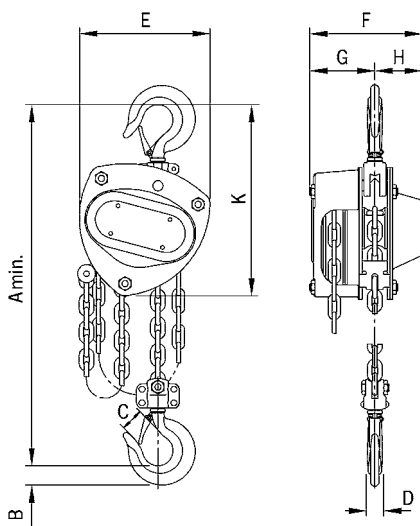

Model VSIII, 250 - 3000 kg, single fall

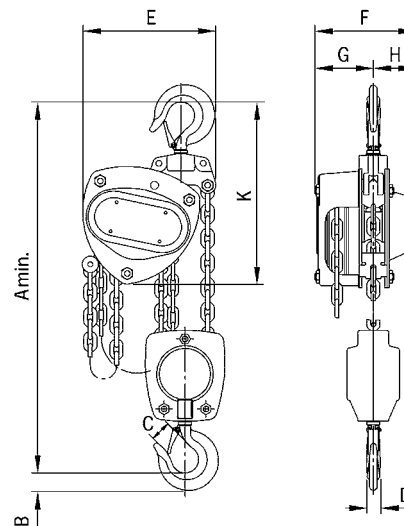

Model VSIII, 2000 - 5000 kg, double fall



Option: Chain container

## INFO

Yale hoists and trolleys are not designed for passenger elevation applications and must not be used for this purpose.



Depicted rubber buffers are available optionally.



Available in explosion proof version (please see page 452).

## Hand chain hoist with integrated push or geared type trolley model Yalelift IT

Capacity 500 - 20000 kg

The combination of the Yalelift 360 with a low headroom manual trolley provides even more flexibility in the application of the Yalelift 360.

### Features

- All units of this series up to a capacity of 3000 kg are provided with single chain fall and the min. headroom (Dim. A) has been further reduced. Ideal for applications with low ceilings and limited headroom.
- The proven and almost stepless adjustment system allows quick and easy assembly of the trolley.
- Trolleys up to 5 t are offered for two beam ranges. Range A for a flange width up to 180 mm is standard and covers approx. 80 % of all applications. Conversion to range B for beam width up to 300 mm can be easily accomplished.
- The trolley wheels are designed for a max. beam profile incline of 14 % (DIN 1025 - part 1), excellent rolling features are guaranteed by prelubricated, encapsulated ball bearings.
- Anti-drop and anti-tilt devices as standard.

### Options

- Adjustable overload protection device.
- Chain container
- Rubber buffers
- Corrosion resistant version
- Beam locking device to secure the unloaded trolley in a fixed position on the beam (park position e.g. on ships). Available up to a capacity of 5000 kg.

Technical data model Yalelift ITP/G

Model	EAN-No. 4025092*	Capacity in kg/ number of chain falls	Size	Beam flange width b  mm	Beam flange thickness t max.  mm	Curve radius min.  m	Weight at standard lift (3 m) - P  kg	Weight at standard lift (3 m) - G  kg	Weight at standard lift (3 m) with locking device - P kg	Weight at standard lift (3 m) with locking device - G kg
YLIT 500	*288255	500/1	A	50 - 180	19	0.9	20	24	26	31
YLIT 500	-	500/1	B	180 - 300	19	0.9	21	25	27	32
YLIT 1000	*292221	1000/1	A	50 - 180	19	0.9	27	32	35	40
YLIT 1000	-	1000/1	B	180 - 300	19	0.9	29	33	37	41
YLIT 2000	*291798	2000/1	A	58 - 180	19	1.15	44	49	52	57
YLIT 2000	-	2000/1	B	180 - 300	19	1.15	46	50	54	58
YLIT 3000	*291804	3000/1	A	74 - 180	27	1.5	77	82	86	91
YLIT 3000	-	3000/1	B	180 - 300	27	1.4	79	84	88	93
YLIT 5000	*291828	5000/2	A	98 - 180	27	2.0	125	130	135	140
YLIT 5000	-	5000/2	B	180 - 300	27	1.8	129	134	139	144
YLIT 10000	*080996	10000/3	B	125 - 310	40	1.8	-	202	-	212
YLIT 20000 <sup>1</sup>	*172325	20000/6	B	180 - 310	40	9.5	-	on request	-	on request

<sup>1</sup> Dimensions on request

P in connection with weight = with push trolley      G in connection with weight = with geared trolley



Chain guide



High quality encapsulated ball bearings and sliding bushes for smooth and effortless operation.



The robust stamped steel housing with four stay bolts is resistant to the toughest working conditions.



The precisely machined load sheave ensures accurate movement of the load chain.

INFO

Yale hoists and trolleys are not designed for passenger elevation applications and must not be used for this purpose.



## Dimensions model Yalelift IT

Model	YLIT 500	YLIT 1000	YLIT 2000	YLIT 3000	YLIT 5000	YLIT 10000
A min., mm	245	272	323	382	550	784
A1, mm	158	178	205.5	252	260.5	380
A2, mm	-	-	-	-	-	-
B, mm	17	22	30	38	45	68
C, mm	24	29	35	40	47	68
D, mm	14	19	22	30	37	50
F (Geared trolley), mm	92	92	91	107	149.5	113
H1, mm	24.5	24	23.5	32	30.5	55
I (Push trolley), mm	71.5	71.5	95.5	131	142.5	169
I (Geared trolley), mm	76.5	76.5	98	132.5	148.5	169
L, mm	270	310	360	445	525	430
L1, mm	130	130	150	180	209	200
L2, mm	159	175	207	256	283	261
L3, mm	-	-	-	-	-	-
L4, mm	-	-	-	-	-	-
M, mm	M 18	M 22	M 27	M 30	M 42	M 48
O, mm	60	60	80	112	125	150
P (Geared trolley), mm	108	110	112	112	117	158
T (Area A), mm	280	290	305	320	364	-
T (Area B), mm	400	410	425	440	484	540

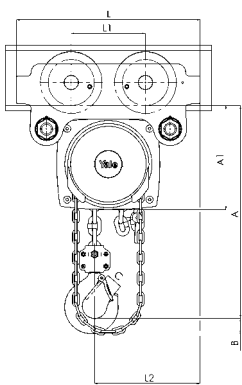

Model Yalelift ITP, 500 - 3000 kg, single fall

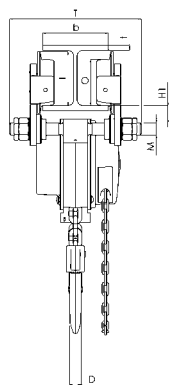

Model Yalelift ITP/ITG, 5000 kg, double fall

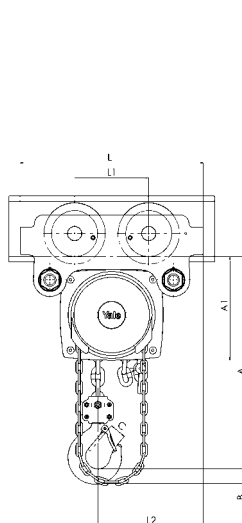
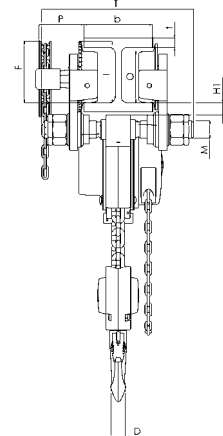
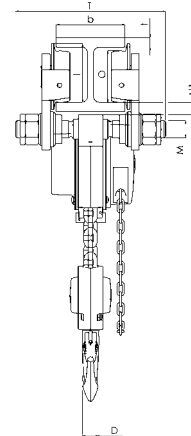
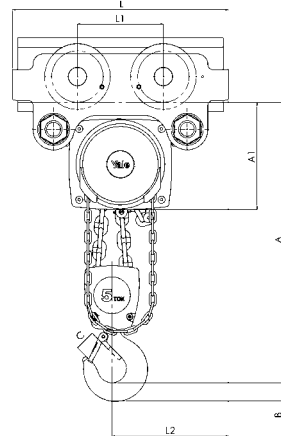

Model Yalelift ITG, 500 - 3000 kg, single fall

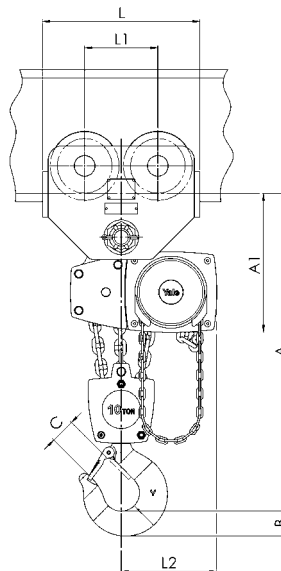
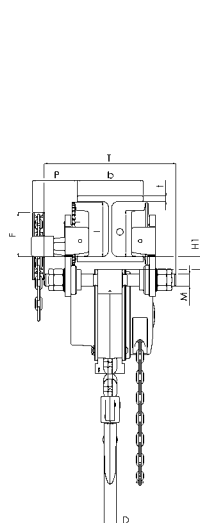

Model Yalelift ITG, 10000 kg, three fall

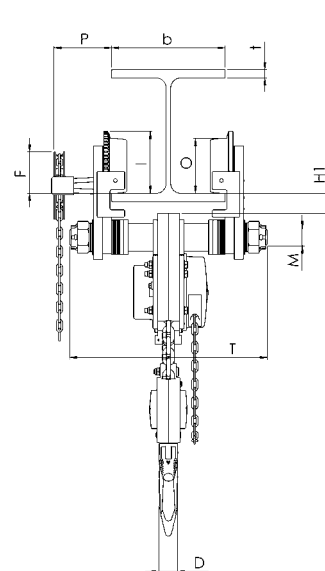

**Hand chain hoist  
with integrated push or geared  
type trolley (low headroom)  
model Yalelift LH**

Capacity 500 - 10000 kg

The hand chain hoist model Yalelift LH with integrated low headroom manual trolley is the consequent further development of the Yalelift IT. Wherever an even smaller headroom is essential, the Yalelift LH is the ideal choice.

**Features**

- The specially developed chain reeving system and chain guide allow the bottom block to be pulled laterally to the hoist even further up and almost against the beam flange.
- The integrated design of the innovative Yalelift LH uses the same manual trolleys as incorporated in the Yalelift IT series.
- All models of the LH series up to 3000 kg capacity are provided with single chain fall.
- The proven and almost stepless adjustment system allows quick and easy assembly of the trolley.
- The trolleys up to 5t are offered for two beam ranges. Range A for a flange width up to 180 mm is standard and covers approx. 80 % of all requirements. Conversion to range B for beam width up to 300 mm can be easily accomplished.
- The trolley wheels are designed for a max. beam profile incline of 14% (DIN 1025 - part 1), excellent rolling features are guaranteed by prelubricated, encapsulated ball bearings.
- The low headroom version of the Yalelift IT is adjustable to fit a wide range of beam profiles (e.g. INP, IPE, IPB).
- Anti-drop and anti-tilt devices as standard.
- Excellent rolling features due to machined steel wheels mounted on pre-lubricated, encapsulated ball bearings.

**Options**

- Adjustable overload protection device.
- Chain container
- Corrosion resistant version.
- Beam locking device to secure the unloaded trolley in a fixed position on the beam (park position e.g. on ships).



Available in explosion proof version (please see page 456).

## Technical data model Yalelift LH

Model	EAN-No. 4025092*	Capacity in kg/ number of chain falls	Size	Beam flange width b	Beam flange thickness t max.	Curve radius min.	Weight at standard lift (3 m) - P	Weight at standard lift (3 m) - G	Weight at standard lift (3 m) with locking device - P kg	Weight at standard lift (3 m) with locking device - G kg
				mm	mm	m	kg	kg		
YLLH 500	*293082	500/1	A	60 - 180	19	0.9	27	31	33	38
YLLH 500	-	500/1	B	180 - 300	19	0.9	27	32	34	38
YLLH 1000	*293167	1000/1	A	70 - 180	19	0.9	35	40	43	48
YLLH 1000	-	1000/1	B	180 - 300	19	0.9	36	41	44	49
YLLH 2000	*319676	2000/1	A	82 - 180	19	1.15	61	65	69	73
YLLH 2000	-	2000/1	B	180 - 300	19	1.15	62	67	70	75
YLLH 3000	*319669	3000/1	A	100 - 180	19	1.5	107	112	116	121
YLLH 3000	-	3000/1	B	180 - 300	19	1.4	109	114	118	123
YLLH 5000	*319652	5000/2	A	110 - 180	27	2.0	152	157	162	167
YLLH 5000	-	5000/2	B	180 - 300	27	1.8	156	161	166	171
YLLH 10000	-	10000/3	A	125 - 210	40	1.8	224	230	234	239
YLLH 10000	-	10000/3	B	190 - 310	40	1.8	227	232	237	242

P in connection with weight = with push trolley  
G in connection with weight = with geared trolley

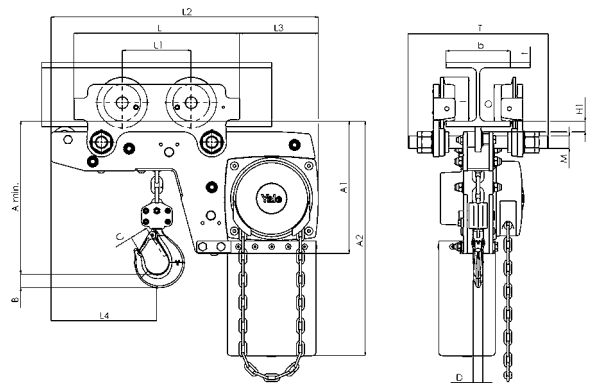

Model Yalelift LHP, 500 - 3000 kg, single fall

## INFO

Yale hoists and trolleys are not designed for passenger elevation applications and must not be used for this purpose.

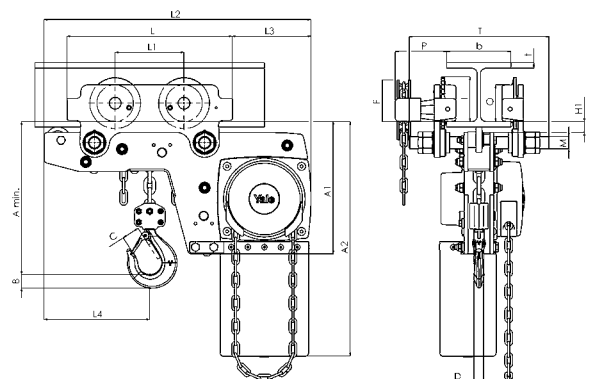

Model Yalelift LHG, 500 - 3000 kg, single fall

Dimensions model Yalelift LH

Model	YLLH 500	YLLH 1000	YLLH 2000	YLLH 3000	YLLH 5000	YLLH 10000
A min., mm	188	211	264	316	425	565
A1, mm	223	250	289	346	345	365
A2, mm	381	427	511	614	612	665
B, mm	17	22	30	38	45	68
C, mm	24	29	35	40	47	68
D, mm	14	19	22	30	37	50
F (Geared trolley), mm	92	92	91	107	150	150
H1, mm	24	24	24	32	31	45
I (Push trolley), mm	72	72	96	131	143	170
I (Geared trolley), mm	77	77	98	133	149	170
L, mm	270	310	360	445	525	485
L1, mm	130	130	150	180	209	225
L2, mm	444	488	582	690	720	805
L3, mm	124	135	172	203	175	215
L4, mm	184	201	230	265	283	348
M, mm	M 18	M 22	M 27	M 30	M 42	M 48
O, mm	60	60	80	112	125	150
P (Geared trolley), mm	108	110	112	112	117	165
T (Area A), mm	280	290	305	320	364	440
T (Area B), mm	400	410	425	440	484	540

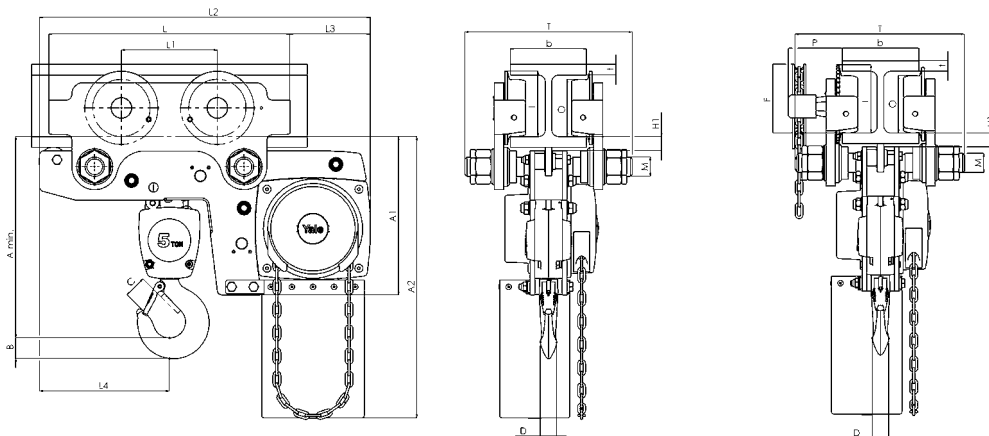

Model Yalelift LHP/LHG, 5000 kg, double fall

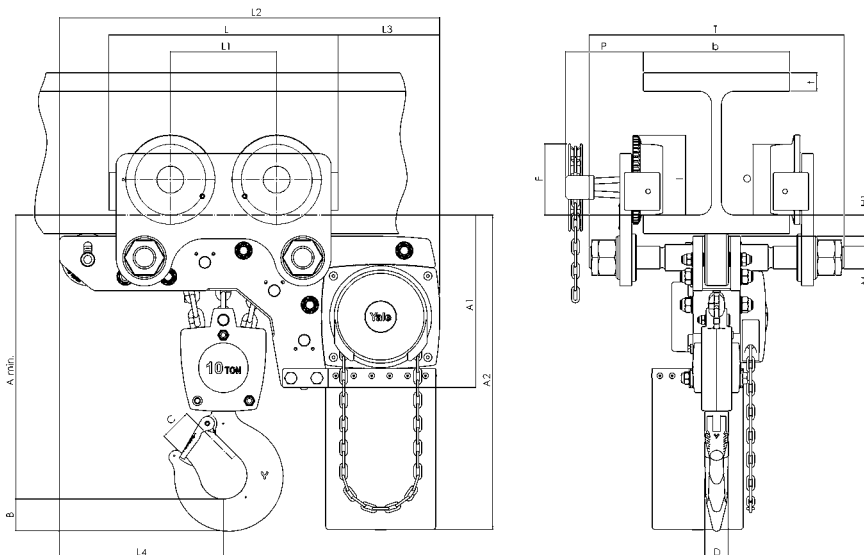

Model Yalelift LHG, 10000 kg, three fall



### Swivel truck low headroom trolley hoist suitable for extreme curve radius model VLRP and model VLRG

Capacity 250 - 6000 kg

The hand chain hoist series VLR with integrated manual trolley drive features extremely low headroom capabilities and provides optimal usage of the available storage space in confined areas.

Hand wheel and gear case are positioned outside the reach of the bottom flange, thus allowing the bottom block to be raised almost until the underside of the beam. The swivel truck feature of the trolley suspension enables travelling on extremely short radius curves.

#### Features

- All-steel construction with zinc-plated load and hand chains.
- The integrated swivel truck trolley suspension permits application on runways with extremely narrow radii.
- All units are built to order for a predetermined beam dimension. They cannot be adjusted retro-actively to other beam sizes.
- Anti-drop and anti-tilt devices as standard.
- The rotating hand chain guide allows side-pull of the trolley hand chain in travel direction.

#### Options

- Overload protection device
- Chain container
- Buffers

## INFO

---

Yale hoists and trolleys are not designed for passenger elevation applications and must not be used for this purpose.

Beam profile and dimension as well as curve radius must always be specified when ordering.



**Compact low headroom trolley hoist with integrated manual trolley model VNRP and model VNRG**

Capacity 1500 - 24000 kg

On account of a special chain reeving system and corresponding chain guide the trolley hoist series VNR offers minimum headroom and maximum usage of the available room height. These hoists have been specially designed for heavy industrial applications.

**Features**

- All-steel construction with zinc-plated load and hand chains.
- All units are built to order for a predetermined beam dimension. They cannot be adjusted retro-actively to other beam sizes.
- Anti-drop and anti-tilt devices as standard.

**Options**

- Chain container
- Buffers



*extremely low headroom for confined spaces*



**Swivel truck trolley with low headroom and extremely short curve radius model VLHP and model VLHG**

Capacity 250 - 6000 kg

The manual trolley series VLH features extremely low headroom. The swivel truck construction allows negotiation of very short curve radius.

**Features**

- All-steel construction with low headroom
- All units are built to order for a predetermined beam dimension. They cannot be adjusted retro-actively to other beam sizes.
- Anti-drop and anti-tilt devices as standard.

**Options**

- Buffers
- Large variety of special versions.



Available in explosion proof version (see page 452).

## Corrosion protection CR

### More life expectancy.

All models of the Yalelift programme can be supplied with corrosion resistant features which include zinc-plated load chain and stainless steel hand chain as standard.

### Corrosion protection

Corrosion starts on the surface of components due to reaction of environmental influences. This affects the mechanical properties of the components, e.g. breaking load and total ultimate elongation.

Many components are supplied in black (unmachined), bright (machined) or painted condition. This offers certain protection but after only a short period of time corrosion can begin.

With the application of a protective coating, the development of corrosion can be reduced and delayed, thus extending the service life of the treated components.

### Applications

Completely corrosion resistant units with either zinc-plated or stainless steel hand and load chains should be used in all conditions with increased requirements towards corrosion protection.

Typical applications are in food processing (e.g. dairy, abattoir, etc.), chemical industries (e.g. paper, dye industries), farming and sewage treatment.

## Locking device

### More grip.

Yale trolleys can be delivered with a locking device to secure the unit (Parking position, e.g. shipping industry).

## Chain container

### More comfort.

The chain containers for the Yalelift programme consist of a robust, powder-coated steel frame with a flexible chain bag made from high tensile Cordura textile fabric. Available in different sizes. Special sizes on request.

## Overload protection

### More control.

The overload protection device of the Yalelift programme reliably prevents excessive load take-up of the hoist during operation. The overload protection device provides additional safety with regard to possible false estimation of the load weight and thus increases the lifetime of the hoist.

## Beam clamp model YC

Capacity 1000 - 10000 kg

Provides a quick and versatile rigging point for hoisting equipment, pulley blocks or loads. Flexible application due to wide adjustment range. The central threaded spindle allows easy attachment and a safe and secure grip. The spindle can be secured against loosening.



## INFO

Yale hoists and trolleys are not designed for passenger elevation applications and must not be used for this purpose.

### Technical data model YC

Model	EAN-No. 4025092*	Capacity kg	Beam flange width mm	Weight kg
YC 1	*055154	1000	75 - 230	3.8
YC 2	*055161	2000	75 - 230	4.6
YC 3	*055192	3000	80 - 320	9.2
YC 5	*055208	5000	90 - 320	11.0
YC 10	*055215	10000	90 - 320	17.2

### Dimensions model YC

Model	YC 1	YC 2	YC 3	YC 5	YC 10
A min., mm	115	115	180	180	175
A max., mm	150	150	225	225	220
A1, mm	78	78	80	90	90
A2, mm	246	246	320	310	320
B1, mm	186	186	232	242	268
B2, mm	350	350	455	445	480
b1, mm	75	75	80	90	90
b2, mm	230	230	320	310	320
C, mm	50	50	70	70	70
D, mm	4	6	8	10	14
E, mm	215	215	255	255	275
F1, mm	34	35	35	35	35
F2, mm	17	18	21	21	20
G1, mm	82	82	120	116	110
G2, mm	44	44	75	75	66
H, mm	20	20	22	28	38
J1, mm	14	14	30	30	34
J2, mm	21	21	34	34	35
K1, mm	48	50	60	60	60
K2, mm	31	32	40	42	40
L, mm	84	94	122	129	146

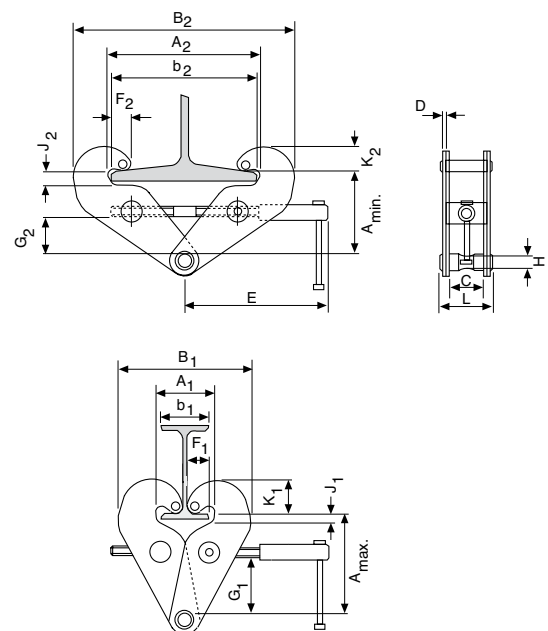





### Push and geared type trolley model HTP and model HTG

Capacity 500 - 20000 kg

The trolley enables the exact positioning or easy traversing of large loads with either manual or powered hoisting equipment.

#### Features

- It has excellent rolling features due to machined steel wheels mounted on prelubricated, encapsulated ball bearings.
- Adjustable to fit a wide range of beam widths and profiles (e.g. INP, IPE and IPB).
- Adjustments are made by rotating the clevis load bar which also ensures the centred positioning of the hoist in the clevis – no creeping to the left or the right.
- The trolley wheels are designed for a max. beam profile incline of 14% (DIN 1025 - part 1).

#### Options

- Rotating hand chain guide.
- Stainless steel hand chains.
- Buffers
- Corrosion resistant version.
- Locking device to secure the trolley in position on the beam (park position e.g. on ships).

## INFO

---

Yale hoists and trolleys are not designed for passenger elevation applications and must not be used for this purpose.

## Technical data model HTP

Model	EAN-No. 4025092*	Capacity kg	Size	Beam flange width b mm	Beam flange thickness t max. mm	Curve radius min. m	Hand effort at WLL daN	Weight kg	Weight with locking device kg
HTP 500	*054874	500	A	50 - 220	25	0.9	-	8.0	14.5
HTP 1000	*054881	1000	A	50 - 220	25	0.9	-	9.0	17.0
HTP 2000	*054898	2000	A	66 - 220	25	1.15	-	16.0	24.0
HTP 3000	*054904	3000	A	74 - 220	25	1.4	-	32.0	41.2
HTP 5000	*054911	5000	A	90 - 220	25	1.8	-	48.0	58.5
HTP 500	*054928	500	B	160 - 300	40	0.9	-	10.6	17.1
HTP 1000	*054935	1000	B	160 - 300	40	0.9	-	12.0	20.0
HTP 2000	*054942	2000	B	160 - 300	40	1.15	-	19.3	27.3
HTP 3000	*054959	3000	B	160 - 300	40	1.4	-	35.8	45.0
HTP 5000	*054966	5000	B	180 - 300	40	1.8	-	52.2	62.7

## Technical data model HTG

Model	EAN-No. 4025092*	Capacity kg	Size	Beam flange width b mm	Beam flange thickness t max. mm	Curve radius min. m	Hand effort at WLL daN	Weight <sup>1</sup> kg	Weight <sup>1</sup> with locking device kg
HTG 500	*074711	500	A	50 - 220	25	0.9	3	9.7	16.2
HTG 1000	*074728	1000	A	50 - 220	25	0.9	6	11.2	19.2
HTG 2000	*074735	2000	A	66 - 220	25	1.15	7	18.0	26.0
HTG 3000	*074742	3000	A	74 - 220	25	1.4	7	35.4	44.6
HTG 5000	*074759	5000	A	90 - 220	25	1.8	9	51.8	62.3
HTG 500	*074766	500	B	160 - 300	40	0.9	3	12.6	19.1
HTG 1000	*074841	1000	B	160 - 300	40	0.9	6	14.1	22.1
HTG 2000	*074773	2000	B	160 - 300	40	1.15	7	21.3	29.3
HTG 3000	*074780	3000	B	160 - 300	40	1.4	7	39.2	48.4
HTG 5000	*074797	5000	B	180 - 300	40	1.8	9	56.0	66.5
HTG 8000	*074803	8000	B	125 - 310	40	1.8	14	104.0	-
HTG 10000	*074810	10000	B	125 - 310	40	1.8	14	104.0	-
HTG 15000	*074827	15000	B	125 - 310	40	5.0	29	230.0	-
HTG 20000	*074834	20000	B	125 - 310	40	5.0	29	230.0	-

<sup>1</sup>Weight HTG: without hand chain



Available in explosion proof version  
(see page 460).

# Hoisting Equipment Trolleys

## Dimensions model HTP

Model	HTP 500-A	HTP 1000-A	HTP 2000-A	HTP 3000-A	HTP 5000-A	HTP 500-B	HTP 1000-B	HTP 2000-B	HTP 3000-B	HTP 5000-B
A, mm	77	82.5	98.5	114	132.5	92	97.5	113.5	129	147.5
D, mm	16	17	22	26	33	16	17	22	26	33
D1, mm	25	30	40	48	60	25	30	40	48	60
D2, mm	30	35	47	58	70	30	35	47	58	70
F1, mm	46	46	46	46	45.5	46	46	46	46	45.5
H1, mm	30.5	30.5	30.5	30	30	45.5	45.5	45.5	45	45
I (HTP), mm	71.5	71.5	95.5	131	142.5	71.5	71.5	95.5	131	142.5
L, mm	260	260	310	390	450	260	260	310	390	450
L1, mm	130	130	150	180	209	130	130	150	180	209
O, mm	60	60	80	112	125	60	60	80	112	125
P1, mm	168	168	168	168	168	168	168	168	168	168
P2, mm	146	150	155	160	167.5	187	187	189.5	191.5	191.5
L3, mm	346	346	396	476	556	346	346	396	476	556

## Dimensions model HTG

Model	HTG 500-A	HTG 1000-A	HTG 2000-A	HTG 3000-A	HTG 5000-A	HTG 500-B	HTG 1000-B	HTG 2000-B	HTG 3000-B	HTG 5000-B	HTG 8000-B	HTG 10000-B	HTG 15000-B	HTG 20000-B
A, mm	77	82.5	98.5	114	132.5	92	97.5	113.5	129	147.5	276	276	270	270
B, mm	-	-	-	-	-	-	-	-	-	-	52	52	70	70
D, mm	16	17	22	26	33	16	17	22	26	33	30	30	35	35
D1, mm	25	30	40	48	60	25	30	40	48	60	80	80	110	110
D2, mm	30	35	47	58	70	30	35	47	58	70	114	114	155	155
F (HTG), mm	91.5	91.5	90.5	107.5	149.5	91.5	91.5	90.5	107.5	149.5	113	113	113	113
F1, mm	46	46	46	46	45.5	46	46	46	46	45.5	77	77	-	-
H1, mm	30.5	30.5	30.5	30	30	45.5	45.5	45.5	45	45	45	45	45	45
I (HTG), mm	76.5	76.5	98	132.5	148.5	76.5	76.5	98	132.5	148.5	170	170	170	170
L, mm	260	260	310	390	450	260	260	310	390	450	430	430	870	870
L1, mm	130	130	150	180	209	130	130	150	180	209	200	200	200	200
L2, mm	-	-	-	-	-	-	-	-	-	-	-	-	115	115
O, mm	60	60	80	112	125	60	60	80	112	125	150	150	150	150
P (HTG), mm	110	110	110	110	110	110	110	110	110	110	163	163	163	163
P1, mm	168	168	168	168	168	168	168	168	168	168	193	193	-	-
P2, mm	146	150	155	160	167.5	187	187	189.5	191.5	191.5	-	-	-	-
T, mm	-	-	-	-	-	-	-	-	-	-	270	270	270	270
L3, mm	346	346	396	476	556	346	346	396	476	556	536	536	976	976
P3, mm	194	194	194	195	195	194	194	194	195	195	-	-	-	-

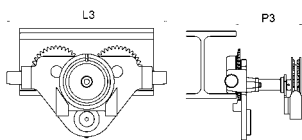

Model HTG 500 - 5000 kg with rotating hand chain guide and buffers

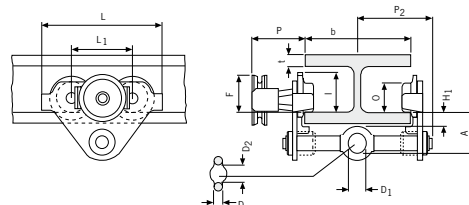

Model HTP/G 500 - 5000 kg

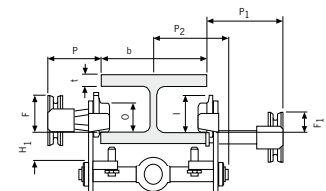

Model HTP/G 500 - 5000 kg, with locking device

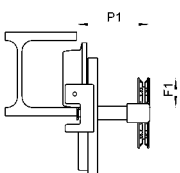

Model HTG 10000 kg, locking device

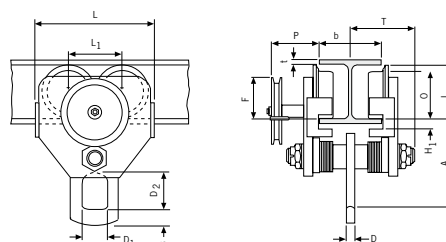

Model HTG 10000 kg

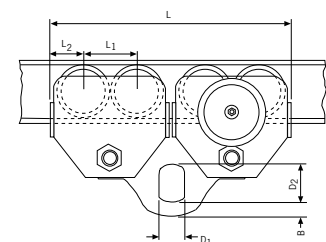

Model HTG 20000 kg

## Trolley clamp model CTP

Capacity 1000 - 3000 kg

Easy fitting to overhead beams for the attachment and transport of loads.

### Features

- Central threaded spindle provides quick adjustment to the required beam width.
- Threaded spindle and clevis are zinc-plated for added corrosion protection.



### Technical data model CTP

Model	EAN-No. 4025092*	Capacity kg	Beam flange width b mm	Curve radius min. m	Weight kg
CTP 1-A	*063012	1000	60 - 150	0.6	2.5
CTP 2-A	*055437	2000	75 - 200	0.9	9.9
CTP 2-B	*055444	2000	200 - 300	0.9	10.3
CTP 3-A	*055451	3000	75 - 200	1.15	17.5
CTP 3-B	*055468	3000	200 - 320	1.15	19.5

### Dimensions model CTP

Model	CTP 1-A	CTP 2-A	CTP 2-B	CTP 3-A	CTP 3-B
A, mm	82 - 109	106 - 155	136 - 191	128 - 171	150 - 212
D, mm	26	42	42	50	50
E, mm	22	20	20	22	22
H1, mm	20	24	24	30.5	30.5
I, mm	53	71.5	71.5	95.5	95.5
L, mm	160	260	260	310	310
L1, mm	75	130	130	150	150
M, mm	M12	M18	M18	M24	M24
O, mm	46	60	60	80	80
P, mm	153	205	255	220	280
T, mm	105	139	189	155	215
tmax., mm	15	25	25	25	25

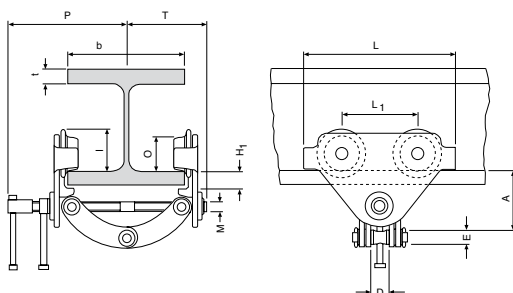

### INFO

Yale hoists and trolleys are not designed for passenger elevation applications and must not be used for this purpose.



## Electric trolley model VTE-U

### Capacity 1000 - 5000 kg

Specially recommended for loads over 1000 kg, for transporting over long distances and/or when used frequently. Suitable for almost all hoists with suspension hook due to universal shackle connection.

Travel motor with worm gear transmission ensures smooth start and self braking – a separate motor brake is not required.

### Features

- Standard operating voltage:  
Euro-voltage 400V, 3-phase, 50 Hz.  
Single speed motors can be reconnected to 230V, 3-phase, 50 Hz.
- Motor protected to IP55 against dust and water jets.  
Push-button pendant control IP65.
- Compact, robust frame with low overall height.
- Wheels manufactured from fracture-proof steel. Smooth running due to machined surfaces and ball bearing mounting. Cambered profile suitable for flat and inclined beam profiles.
- Anti-drop and anti-tilt devices as standard.
- Easy adjusted to fit to a wide range of beam widths and profiles due to threaded spindles.

### Options

- Low voltage control (42V)
- Rubber buffers
- 230V, 1-phase, 50 Hz



Wheel with cambered profile



Threaded spindle



Anti-drop device with option to fit buffers.

## INFO

Yale hoists and trolleys are not designed for passenger elevation applications and must not be used for this purpose.

## Technical data model VTE-U

Model	EAN-No. 4025092*	Capacity kg	Travel speed m/min	Motor kW	Beam flange width mm	Beam flange thickness t max. mm	Curve radius min. m	Weight kg
VTE 1-A-18/U <sup>1</sup>	*073547	1000	18 or 18/4.5	0.18 or 0.18/0.06	58 - 180	19	0.9	19.5
VTE 1-B-18/U <sup>1</sup>	*073585	1000	18 or 18/4.5	0.18 or 0.18/0.06	180 - 300	19	0.9	25.2
VTE 2-A-18/U <sup>1</sup>	*073561	2000	18 or 18/4.5	0.18 or 0.18/0.06	58 - 180	19	1.15	26.0
VTE 2-B-18/U <sup>1</sup>	*073608	2000	18 or 18/4.5	0.18 or 0.18/0.06	180 - 300	19	1.15	30.2
VTE 3-A-11/U	*073424	3000	11 or 11/2.8	0.37 or 0.3/0.09	74 - 180	27	1.5	51.0
VTE 3-B-11/U	*073509	3000	11 or 11/2.8	0.37 or 0.3/0.09	180 - 300	27	1.4	53.0
VTE 5-A-11/U	*073448	5000	11 or 11/2.8	0.37 or 0.3/0.09	98 - 180	27	2.0	77.0
VTE 5-B-11/U	*073523	5000	11 or 11/2.8	0.37 or 0.3/0.09	180 - 300	27	1.8	80.0

<sup>1</sup> 11 or 11/2.8m/min. travel speed on request

## Dimensions model VTE-U

Model	VTE 1-A-18/U	VTE 1-B-18/U	VTE 2-A-18/U	VTE 2-B-18/U	VTE 3-A-11/U	VTE 3-B-11/U	VTE 5-A-11/U	VTE 5-B-11/U
A, mm	113	113	115	115	139	139	161	161
B, mm	b + 50	b + 50	b + 54	b + 54	b + 60	b + 60	b + 70	b + 70
C, mm	49	49	47	47	57	57	60	60
D, mm	16	16	16	16	19	19	22	22
E, mm	187	187	187	187	202	202	202	202
F, mm	94	94	94	94	94	94	94	94
G, mm	43	43	43	43	51	51	58	58
H, mm	129	129	128	128	144	144	178	178
H1, mm	24	24	24	24	32	32	32	32
I, mm	77	77	98	98	133	133	149	149
L1, mm	130	130	150	150	180	180	209	209
M, mm	155	155	180	180	208	208	263	263
N single speed, mm	255	255	255	255	292	292	292	292
N double speed, mm	263	263	263	263	296	296	296	296
O, mm	60	60	80	80	112	112	125	125
P, mm	123	123	123	123	129	129	121	121
Q, mm	145	205	153	213	160	220	182	242

